



1769 Weigh Scale Module

Model HM1525

Instruction Manual *HM1525_Rev4.0.PDF*

March, 2026

HM1525 Weigh Scale Module

Important User Information

Solid state equipment has operational characteristics differing from those of electromechanical equipment. “Safety Guidelines for the Application, Installation and Maintenance of Solid State Controls” (Allen-Bradley Publication SGI-1.1) describes some important differences between solid state equipment and hard-wired electromechanical devices. Because of this difference, and also because of the wide variety of uses for solid state equipment, all persons responsible for applying this equipment must satisfy themselves that each intended application of this equipment is acceptable.

In no event will the Allen-Bradley Company or Helm Instrument Company be responsible or liable for indirect or consequential damages resulting from the use or application of this equipment.

The examples and diagrams in this manual are included solely for illustrative purposes. Because of the many variables and requirements associated with any particular installation, the Allen-Bradley Company or Helm Instrument Company cannot assume responsibility or liability for actual use based on the examples and diagrams.

No patent liability is assumed by Allen-Bradley Company or Helm Instrument Company with respect to use of information, circuits, equipment, or software described in this manual.

Reproduction of the contents of this manual, in whole or in part, without written permission of the Allen-Bradley Company and Helm Instrument Company is prohibited.

Throughout this manual we use note to make you aware of safety considerations.



ATTENTION: Identifies information about practices or circumstances that can lead to property damage. Identifies information that is especially important for successful application and understanding of the product.

Attentions help you:

- identify a hazard
- avoid the hazard
- recognize the consequences



ATTENTION: Please check power supply ratings before proceeding! Each tonnage module consumes (+24, 50mA +5, 66mA). Be sure to not overload the power supply.

HM1525 Weigh Scale Module

Preface

Read this preface to familiarize yourself with the rest of this manual. This preface covers the following topics:

- who should use this manual
- the purpose of this manual
- terms and abbreviations
- conventions used in this manual
- Allen-Bradley support

Who Should Use this Manual?

Use this manual if you are responsible for the design, installation, programming, or maintenance of an automation control system that used Allen-Bradley small logic controllers.

You should understand electronic process control and be able to interpret the ladder logic instructions required to generate the electronic signals that control your application. If you do not, contact your local Allen-Bradley representative for the proper training before using this product.

Purpose of This Manual

This manual is a learning and reference guide for the Helm Weigh Scale Module. It contains the information you need to install, wire, and use the module.

HM1525 Weigh Scale Module

ATTENTION

Environment and Enclosure

This equipment is intended for use in a Pollution Degree 2 industrial environment, in overvoltage Category II applications (as defined in IEC publication 60664-1), at altitudes up to 2000 meters without derating.

This equipment is considered Group 1, Class A industrial equipment according to IEC/CISPR Publication 11. Without appropriate precautions, there may be potential difficulties ensuing electromagnetic compatibility in other environments due to conducted as well as radiated disturbance.

This equipment is supplied as "open type" equipment. It must be mounted within an enclosure that is suitably designed for those specific environmental conditions that will be present and appropriately designed to prevent personal injury resulting from accessibility to live parts. The interior of the enclosure must be accessible only by the use of a tool. Subsequent sections of this publication may contain additional information regarding specific enclosure type ratings that are required to comply with certain product safety certifications.

See NEMA Standards publication 250 and IEC publication 60529, as applicable, for explanations of the degrees of protection provided by different types of enclosure. Also, see the appropriate sections in this publication, as well as the Allen-Bradley publication 1770-4.1 ("Industrial Automation Wiring and Grounding Guidelines"), for additional installation requirements pertaining to this equipment.

ATTENTION

POINT I/O is grounded through the DIN rail to chassis ground. Use zinc plated, yellow chromated steel DIN rail to assure proper grounding. Using other DIN rail materials (e.g. aluminum, plastic, etc.) which can corrode, oxidize or are poor conductors can result in improper or intermittent platform grounding.

HM1525 Weigh Scale Module

WARNING**EXPLOSION HAZARD**

- Do not disconnect equipment unless power has been removed or the area is known to be nonhazardous.
 - Do not disconnect connections to this equipment unless power has been removed or the area is known to be nonhazardous. Secure any external connections that mate to this equipment by using screws, sliding latches, threaded connectors, or other means provided with this product.
 - Substitution of components may impair suitability for Class I, Division 2.
 - If this product contains batteries, they must only be changed in an area known to be nonhazardous.
-

ATTENTION**Preventing Electrostatic Discharge**

This equipment is sensitive to electrostatic discharge, which can cause internal damage and affect normal operation. Follow these guidelines when you handle this equipment:

- Touch a grounded object to discharge potential static.
 - Wear an approved grounding wriststrap.
 - Do not touch connectors or pins on component boards.
 - Do not touch circuit components inside the equipment.
 - If available, use a static-safe workstation.
 - When not in use, store the equipment in appropriate static-safe packaging.
-

HM1525 Weigh Scale Module

Installing the Mounting Base

To install the mounting base on the DIN rail, proceed as follows.

1. Position the mounting base vertically above the installed units (adapter, power supply or existing module).
2. Slide the mounting base down allowing the interlocking side pieces to engage the adjacent module or adapter.
3. Press firmly to seat the mounting base on the DIN rail. The mounting base will snap into place.
4. To remove the mounting base from the DIN rail, remove the module, and use a small bladed screwdriver to rotate the base locking screw to a vertical position. This releases the locking mechanism. Then lift straight up to remove.

Installing the I/O Module

The module can be installed before, or after base installation. Make sure that the mounting base is correctly keyed before installing the module into the mounting base. In addition, make sure the mounting base locking screw is positioned horizontal referenced to the base.

WARNING

When you insert or remove the module while backplane power is on, an electrical arc can occur. This could cause an explosion in hazardous location installations. Be sure that power is removed or the area is nonhazardous before proceeding.

-
1. Using a bladed screwdriver, rotate the keyswitch (2) on the mounting base clockwise until the number required for the type of module being installed aligns with the notch in the base.
 2. Make certain the DIN rail locking screw is in the horizontal position. (You cannot insert the module if the locking mechanism is unlocked.)

HM1525 Weigh Scale Module

3. Insert the module straight down into the mounting base and press to secure. The module will lock into place.

Installing the Removable Terminal Block (RTB)

A removable terminal block is supplied with your wiring base assembly. To remove, pull up on the RTB handle. This allows the mounting base to be removed and replaced as necessary without removing any of the wiring. To reinsert the removable terminal block, proceed as follows.

1. Insert the end opposite the handle into the base unit. This end has a curved section that engages with the wiring base.
2. Rotate the terminal block into the wiring base until it locks itself in place.
3. If an I/O module is installed, snap the RTB handle into place on the module.

WARNING

When you connect or disconnect the Removable Terminal Block (RTB) with field side power applied, an electrical arc can occur. This could cause an explosion in hazardous location installations.

Be sure that power is removed or the area is nonhazardous before proceeding.

HM1525 Weigh Scale Module

Removing a Mounting Base

To remove a mounting base, you must remove any installed module, and the module installed in the base to the right. Remove the removable terminal block (if wired).

1. Unlatch the RTB handle on the I/O module.
2. Pull on the RTB handle to remove the removable terminal block.

When you connect or disconnect the Removable Terminal Block (RTB) with field side power applied, an electrical arc can occur. This could cause an explosion in hazardous location installations.

Be sure that power is removed or the area is nonhazardous before proceeding.

3. Press on the module lock on the top of the module.
4. Pull on the I/O module to remove from the base.

When you insert or remove the module while backplane power is on, an electrical arc can occur. This could cause an explosion in hazardous location installations. Be sure that power is removed or the area is nonhazardous before proceeding.

5. Repeat steps 1, 2, 3 and 4 for the module to the right.
6. Use a small bladed screwdriver to rotate the orange base locking screw to a vertical position. This releases the locking mechanism.
7. Then lift straight up to remove.

HM1525 Weigh Scale Module

OUTPUT TAG DESCRIPTIONS

CALMODE

Used for initial installation. All math is disabled, weigh value is not scaled, leaving raw A/D value.

WEIGH MODE

Factory cal setting 100,000 counts = 2MV/V

CLEAR TARE CH1/CH2 Bit

Clears internal tare value for “zero state”.

Useful when troubleshooting load cell wiring or other failures.

TARE CH1/CH2

Sets A/D value to zero.

READ ADTRIM BIT

(HELM Factory setting only).

CH1/CH2 AUTO TUNE BITS

Set to “1” when in auto cal mode

Reference/cal weight on before setting bit

READ SCALE SET BIT

Set to “1” to verify CH1/CH2 scale sets

ENABLE FILTER BITS

Set to “1” to enable 60/50 hz filter

CH1/CH2 FILTER ON BIT

Set to “1” to enable filter

Set to “0” to disable filter

Local:I:O.Data[6].15



1769 EtherNet/IP communication module

Set this bit when using the EtherNet/IP module for remote 1769 I/O. Clear this bit for 1769 I/O, connected to all 1769 Compact Logix PLCs. The default setting for this bit is cleared.

HM1525 Weigh Scale Module

OUTPUT TAG DESCRIPTIONS

MSF BITS – (Motion Stabilization Filter)

Used for applications with constant or static type loads to keep display value stable.

MSF1_2 (1 count up – 2 counts down).

MSF2_4

MSF4_8

MSF5_10

Set one bit only.

ZERO-DEAD-BAND BITS

Useful for Auto-Tare functions with production runs.

Set only one bit.

ZEROBAND_025 = .025% full scale

ZEROBAND_05 = .05% full scale

ZEROBAND_075 = .075% full scale

Auto tare occurs when load cell weight is at bit level or lower.

READ MV/V BIT

Check verify mV/V settings

READ CAL FACTOR BIT

Check auto cal values

SAVE TO EEPROM

Stores CH1/CH2 scale settings

AUTO CAL MODE

Set to “1” for auto cal mode

SET CH1 SCALE BIT

Set to “1” to set CH1 scale

SET CH2 SCALE BIT

Set to “1” to set CH2 scale

HM1525 Weigh Scale Module

REQUIRED CONTROLLER TAGS

CH1/CH2 SCALE SET AND AUTO CAL REFERENCE

CH1_SCALE_MOD1

Full scale setting for CH1, CH2

Value is determined by capacity of load cell and by resolution required.

Example: 10KG = 10,000

GET WEIGH VALUE CH1

CH1_WEIGHT_MOD1

CH2_WEIGHT_MOD1

Reports measured weigh value in RUN mode.

Reports raw A/D count value in CAL mode.

SET AVERAGE SAMPLE COUNT

SMAPLE_SET_MOD1

Set number of samples to take for average type filter.

SET mV/V CH1, CH2

CH1_MV_V MOD1

CH2_MV_V MOD1

CH1/CH2 MV_V Settings

Enter 2000 for 2.0 mV/V

Actual value is from load cell specification.

FILTER TIME _MOD1

FILTER_TIME_MOD1

Each count = 1 msec

50 h2: 20 msec = 20

60 h2: 16 msec = 16

HM1525 Weigh Scale Module

Specifications - HM1734-WM Strain Gage Input Module

Module Location	1734-TOP (screw terminal) or 1734-TOPS (spring loaded terminal)
Type of input	Strain Gage (350 ohm, 700 ohm)
Gage Excitation Voltage	5 Volt
Input Impedance	5.11 meg. ohm
Display Resolution	Up to .0025% of full scale
Module Accuracy	Dependent on Load Cell Specification
Module Update Time	Software selectable from 2ms to 100ms
Number of Channels	2 (isolated)
A/D Conversion Method	Successive Approximation - 24 bit
Normal Mode Rejection:	(between +/- input) 116DB CMRR
Amplifier Bandwidth	200 kHz
Calibration Software	Selectable
Isolation:	500 VDC continuous between inputs and chassis ground, and between input and backplane
LED indicators	2 LED's for Power and Alarm
Recommended Cable	Strain Gage Cable (Helm part number 6117)
Operating Temperatures	0°C to 60°C (32°F to 140°F)
Emissions	CISPR 11 Group 1, Class A
Pointbus Current	5V @ 72ma
External Power	24V @ 19.5ma
Dimensions	2.21H x 0.47W x 2.97L (Millimeters 56H x 12W x 75.5L)

HM1525 Weigh Scale Module

SETTING UP HM1525WM MODULE

Step #1

Add module to project as following:

HM1525WM MODULE PROPERTIES

General Tab Settings

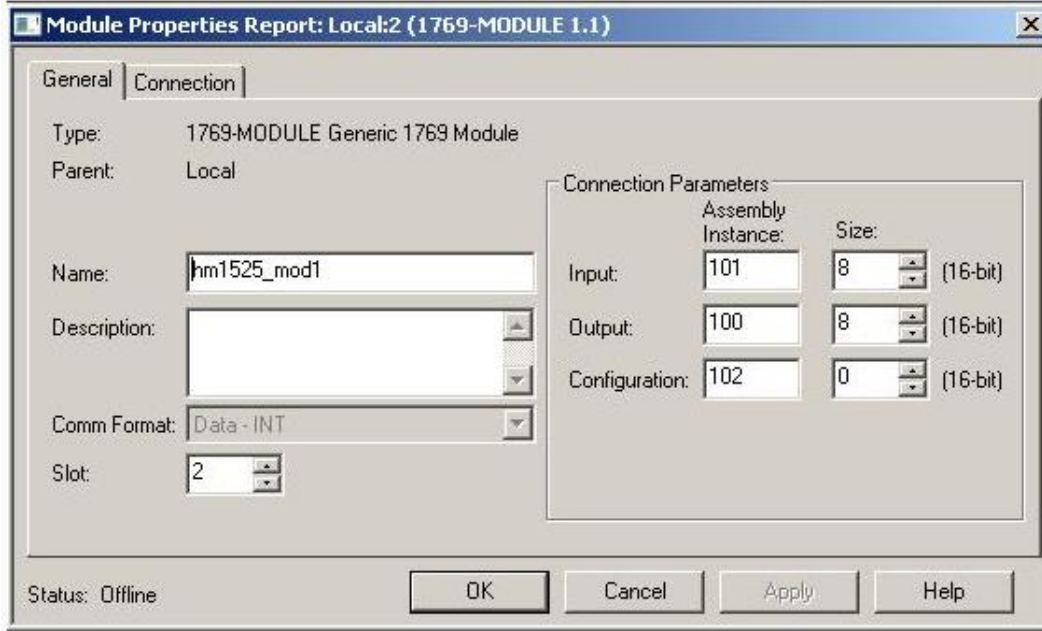

Connection Tab Settings

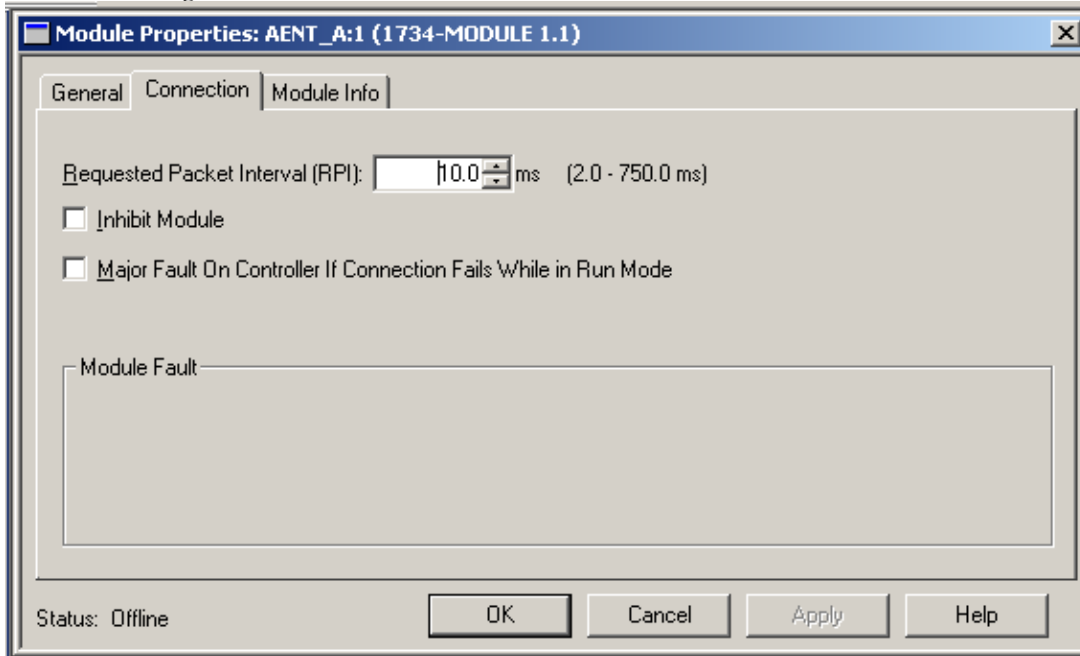

*Be sure to set RPI to 2 ms.

HM1525 Weigh Scale Module

ch1_ch2 - Ladder Diagram

WEIGH_1525:MainTask:weighmodule1

Total number of rungs in routine: 1

Page 1

6/11/2021 3:07:22 PM

C:\RSLogix 5000\Projects\hm1525_template_rev3.ACD

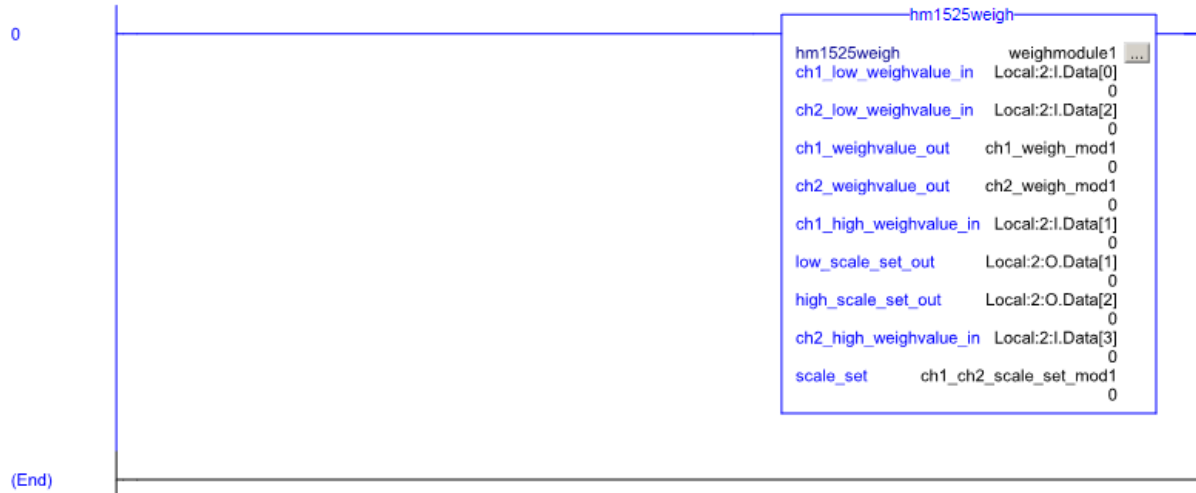

ch1_ch2_scale_set_mod1	0	DINT
ch1_weigh_mod1	0	DINT
ch2_weigh_mod1	0	DINT

Local:2:O.Data[0].0	0	BOOL	cal mode
Local:2:O.Data[0].1	0	BOOL	weigh mode
Local:2:O.Data[0].2	0	BOOL	clear tare ch1
Local:2:O.Data[0].3	0	BOOL	set tare ch1
Local:2:O.Data[0].4	0	BOOL	clear tare ch2
Local:2:O.Data[0].5	0	BOOL	set tare ch2
Local:2:O.Data[0].6	0	BOOL	read mv/v sets
Local:2:O.Data[0].7	0	BOOL	read cal factor
Local:2:O.Data[0].8	0	BOOL	save to eeprom
Local:2:O.Data[0].9	0	BOOL	read adtrim
Local:2:O.Data[0].10	0	BOOL	auto cal mode
Local:2:O.Data[0].11	0	BOOL	set ch1 scale
Local:2:O.Data[0].12	0	BOOL	set ch2 scale
Local:2:O.Data[0].13	0	BOOL	ch1 auto tune
Local:2:O.Data[0].14	0	BOOL	ch2 auto tune
Local:2:O.Data[0].15	0	BOOL	read scale sets
Local:2:O.Data[1]	0	INT	low scale set
Local:2:O.Data[2]	0	INT	high scale set
Local:2:O.Data[3]	0	INT	ch1 mv/v set
Local:2:O.Data[4]	0	INT	ch2 mv/v set
Local:2:O.Data[5]	0	INT	sample set

HM1525 Weigh Scale Module

Local:2:O.Data[6].0	0	BOOL	msf range 1
Local:2:O.Data[6].1	0	BOOL	msf range 2
Local:2:O.Data[6].2	0	BOOL	msf range 4
Local:2:O.Data[6].3	0	BOOL	msf range 5
Local:2:O.Data[6].4	0	BOOL	msf range 6
Local:2:O.Data[6].5	0	BOOL	msf range 7
Local:2:O.Data[6].6	0	BOOL	msf range 8
Local:2:O.Data[6].7	0	BOOL	
Local:2:O.Data[6].8	0	BOOL	zero band range .025
Local:2:O.Data[6].9	0	BOOL	zero band range .050
Local:2:O.Data[6].10	0	BOOL	zero band range .075
Local:2:O.Data[6].11	0	BOOL	enable filter
Local:2:O.Data[6].12	0	BOOL	ch1 filter on
Local:2:O.Data[6].13	0	BOOL	
Local:2:O.Data[6].14	0	BOOL	
Local:2:O.Data[6].15	0	BOOL	ch2 filter on
Local:2:O.Data[7]	0	INT	filter time set

HM1525 Weigh Scale Module

Related Documentation

The following documents contain information that may be helpful to you as you use Allen-Bradley SLC products. To obtain a copy of any of the Allen-Bradley documents listed, contact your local Allen-Bradley office or distributor.

For	Read this Document	Document Number
CompactLogix 5370 L1 Programmable Automation Controllers	CompactLogix 5370 L1 Programmable Automation Controllers	1769-PP012
An overview for the MicroLogix™ Programmable Controllers	MicroLogix 1500 Programmable Controllers	1764-UM001A-US-P
A description on how to install and use your MicroLogix Programmable Controller	MicroLogix 1500 Programmable Controller Base Units Installation Instructions and Wiring Diagrams	1764-IN001A-ML-P
A description on how to install the processor into the MicroLogix 1500 Base unit.	MicroLogix 1500 Processor Installation Instructions	1764-IN002A-ML-P
Selecting Discrete Input/Output Modules	Compact Discrete Input/Output Modules Technical Data	1769-2.1
View power usage of expansion modules to determine power supply requirements	Expansion Modules System Qualifier	RA Website Download
End Cap Installation	Compact I/O End Caps/Terminators Installation Instructions	1769-5.16
A complete listing of current Automation Group documentation, including ordering instructions. Also indicates whether the documents are available on CD-ROM or in multi-languages	Automation Group Publication Index	SD499
A glossary of industrial automation terms and abbreviations	Allen-Bradley Industrial Automation Glossary	ICCG-7.1
An article on wire sizes and types for grounding electrical equipment	National Electrical Code	Published by the National Fire Protection Association of Boston, MA.

HM1525 Weigh Scale Module

Terms and Abbreviation

The following terms and abbreviations are used throughout this manual. For definitions of terms not listed here refer to *Allen-Bradley's Industrial Automation Glossary*, Publication ICCG-7.1.

Calibration - Procedure, performed by trained personnel, where machine or press is dynamically loaded to impact on load cells. A process of linearity measuring to determine the loading capacity of the machine.

Calibration Number - Amplification values established during machine calibration or pre-assigned on force load cells.

Channel - Refers to one of two, strain gage inputs available on the modules terminal block.

Chassis - A hardware assembly that houses devices such as I/O modules, adapter modules, processor modules, and power supplies.

Configuration Word - Contains the channel configuration information needed by the module to configure and operate each channel. Information is written to the configuration word through the logic supplied in your ladder program.

Data Word - A 16-bit integer that represent the value of the analog input channel. The channel data word is valid only when the channel is enabled.

Gain - Amplification of an input signal.

Load/Force - Measurement of impact during a machine cycle. Sensors provide the input for this measurement.

LSB - (Least Significant Bit) Refers to a data increment defined as the full-scale range divided by the resolution. The bit that represents the smallest value within a string of bits.

Remote Configuration - A control system where the chassis can be located several thousand feet from the processor chassis.

Resolution - The smallest detectable change in a measurement, typically expressed in engineering units (e.g. 0.15C) or as a number of bits. For example, a 12-bit system has 4,096 possible output states. It can therefore measure 1 part in 4096.

Sample - Load/force values established from a series of machine cycles. Also defined as benchmark.

Sampling time - The time required by the A/D converter to sample an input channel.

Scale - Value used to describe the press/machine overall tonnage. Set for maximum value of one channel. For example, settings for a 150 ton press = 75.

Status Word - Contains status information about the channel's current configuration and operational state. You can use this information in your ladder program to determine whether the channel data word is valid.

Update Time - The time required for the module to sample and convert the input signals of all enables input channels and make the resulting data values available to the SLC processor.

HM1525 Weigh Scale Module

Common Techniques Used in this Manual

The following conventions are used throughout this manual:

- Bulleted lists such as this one provides information, not procedural steps.
- Numbered lists provide sequential steps or hierarchical information.

Product Support

Contact your Helm representative or call Helm direct at 419-893-4356:

- sales and order support
- product technical training
- warranty support
- support service agreements

Download up to date manuals and ladder logic files at
<http://www.helminstrument.com/manuals-and-downloads/>

Your Questions or Comments on this Manual

If you have any suggestions for how this manual could be made more useful to you, please send us your ideas.

HM1525 Weigh Scale Module

Overview

You have just purchased the most advanced load monitoring solution available. HELM INSTRUMENT COMPANY, INC. manufactures a complete line of load monitoring control solutions for use on metal stamping, forging, compaction and assembly presses; cold forming, cold heating, injection molding and die cast machines.

Standard or custom transducers and load cells are available for in-die monitoring of transfer or progressive tooling.

At HELM, quality is inherent not only in the design of our products but in the attitudes of our employees as well. We're working together to give you the best. After all, that's what our business is all about - providing innovative instrumentation to help make your manufacturing process more productive and your operation more effective.

The Helm Weigh Scale combines machine and tooling monitoring with programmable limit switch function. User programmable high and low limits protect the machine and tooling to ensure part quality.

Critical setup information can be stored and uploaded as part of a die recipe program. An optional resolver input module is used to compare machine/press tonnage to crank angle for real time signature analysis.

Components

The Helm Weigh Scale module is attached to the controller or to an adjacent I/O module on the din rail. The system is comprised of two parts; the input module and strain gage-based sensors and load cells.

HM1525 Weigh Scale Module

Hardware Overview

The Weigh Scale module can be attached to the controller or to an adjacent I/O module before or after din rail mounting. It is a Class 1 module (uses eight input words and eight output words). It interfaces to strain gage-based transducers (350ohm or 700ohm).

The module can accept input from two sensors. The module has no output channels. Module configuration requires manual and user programmable setup.

The Weigh Scale module receives and stores digitally converted analog data into its image table for retrieval by processor. The module supports connections from any combination of up to two strain gage sensors.

Any combination of Helm Strain Gage sensors can be used. Contact Helm for additional information on the type and application of different sensor options.



HM1525 Weigh Scale Module

Getting Started

This chapter can help you to get started using the Helm Weigh Scale module. The procedures included here assume that you have a basic understanding of PLC products. You should understand electronic process control and be able to interpret the ladder logic instructions required to generate the electronic signals that control your application.

Because it is a start-up guide, this chapter does not contain detailed explanations about the procedures listed. It does, however, reference other chapters in this book where you can get more information about applying the procedures described in each step.

If you have any questions or are unfamiliar with the terms used or concepts presented in the procedural steps, always read the referenced chapters and other recommended documentation before trying to apply the information.

This chapter will:

- Tell you what equipment you need
- Explain how to install and wire the module
- Show you how to set channels for the sensor input

Required Tools and Equipment

Have the following tools and equipment ready:

- Small blade screwdriver
- Appropriate strain gage cable
- Programming equipment

HM1525 Weigh Scale Module

System Operation

The Weigh Scale module communicates to the processor through the parallel backplane interface and receives +5Vdc and +24Vdc power from the power supply through the backplane. No external power supply is required. The MicroLogix and CompactLogix platforms can support up to 8 I/O modules. You may install up to 3 Weigh Scale modules using the base power supply. An additional power supply can be added to support more than 3 modules.

Each individual channel on the module can receive input signals from strain gage-based sensors. The module converts the analog values directly into digital values.

Sensor Wiring

The sensors are wired to the modules using the rightmost bank of inputs. The pin-out is shown below.

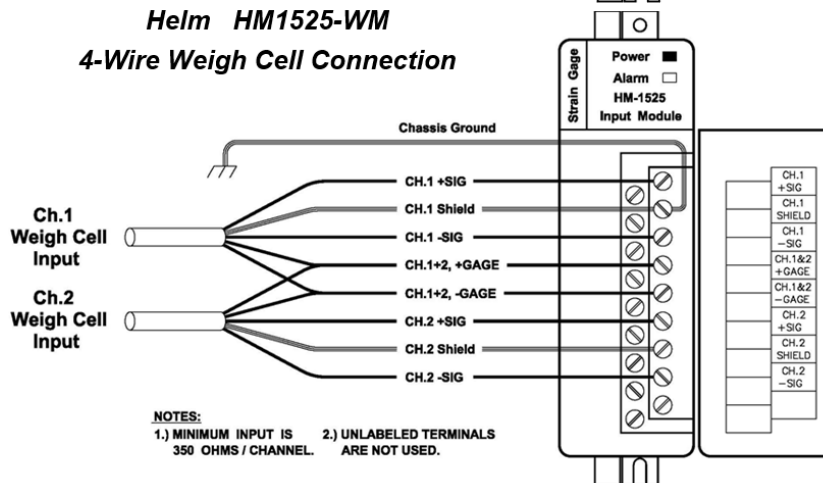
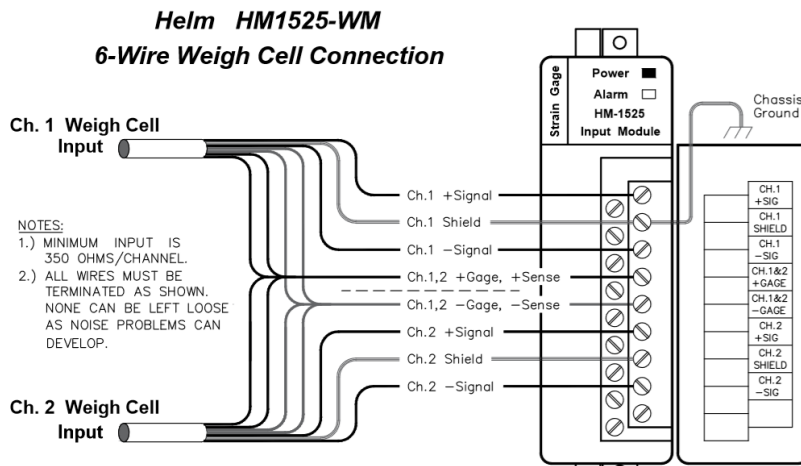



To ensure proper operation and high immunity to electrical noise, always use Helm strain gage cable.

To limit noise, keep strain gage cable as far away as possible from power and load lines.



The module can support up to two sensor inputs.

DO NOT attempt to parallel additional gages as you will cause damage to the module and void product warranty.

HM1525 Weigh Scale Module

Setup Procedure

A complete listing of a sample ladder logic program is included at the back of this manual. Examples shown here are for reference.



All values are 0 (default) on initial start-up. This means that all alarms are disabled. You must make the following adjustments for proper operation:

- Balance sensor input(s)
 - Set Calibration numbers
-

Step 1. Balance Sensor Input.

1. Set to Cal Mode
2. Press Clear Tare for each channel
3. Check balance value, should be 131,000 counts

Step 2. Set Calibration Numbers

1. Set Scale to capacity of load cell
2. Set mV/V to load cell specification
3. Example:
100-ton load cell, 2.025 mV/V
For scale set, enter 100
For mV/V set, enter 2025
4. Push Set CH1, Set CH2 Scale
Push Save to eeprom
5. Set to Run Mode

Automatic Calibration

Auto calibration or Auto-Cal is a process that allows the module to calibrate against a known load without a known mV/V. This process requires a known load to be placed on the loadcell as well as specific tags of each of the channels to be toggled. Below is an example of this process with sample values.



ATTENTION: The following calibration steps are channel specific. Before completing each step, verify that you are working on the intended channel and all required bits are set accordingly.

1. Set AutoCalMode and CalMode (Turn off WeightMode)
2. Enter known load weight in the scale tag
3. Toggle the SetScale tag
4. **Ensure there is no load on the loadcell**
5. Toggle the SetTare tag
6. Apply the known reference load to the loadcell
7. Toggle the AutoCal tag
8. Change mode to Weigh Mode to verify that the calibration worked
9. Toggle SaveToEEPROM tag (Saves calibration value internally)

HT-400 Sensor Ohm Readings:

Green-Black	350 ohms
Red-White	350 ohms
All other color combinations	266 ohms
All colors to Ground	open
Shield to Ground	open

HM1525 Weigh Scale Module

Helm HM1525-WM 6-Wire Weigh Cell Connection

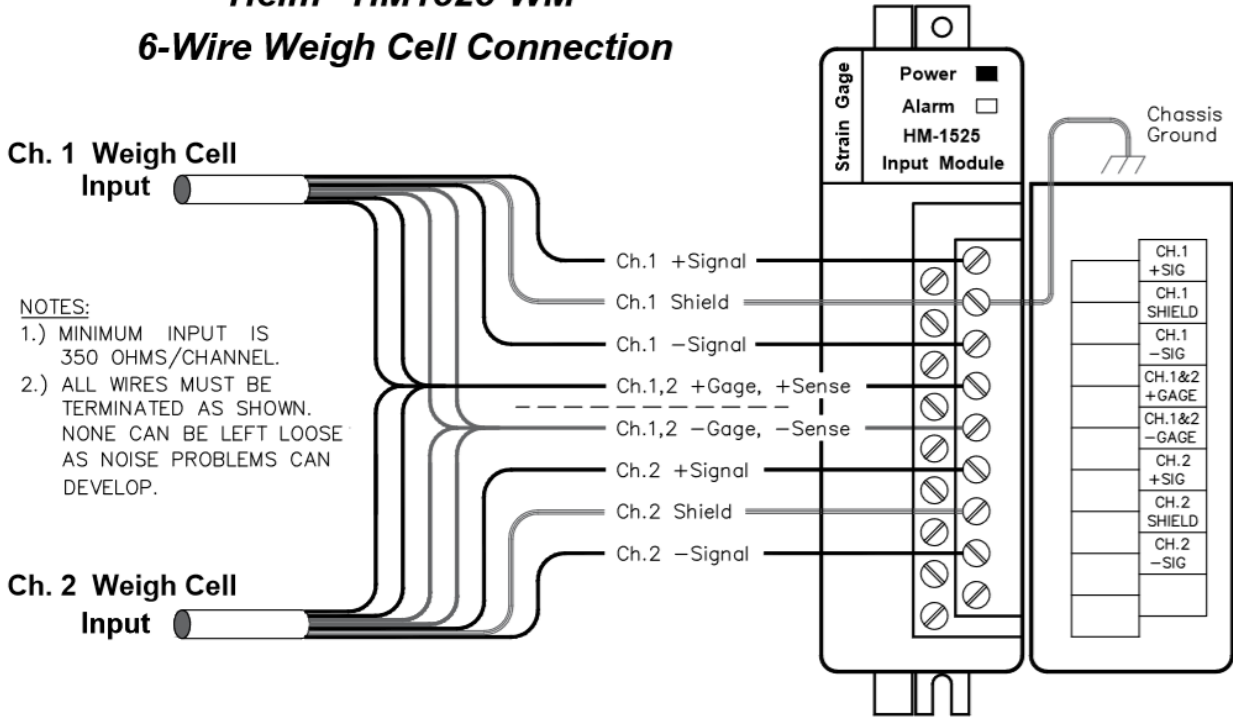

Helm HM1525-WM 4-Wire Weigh Cell Connection

